

Seven steps to citizen development

Building an automation culture in your organization

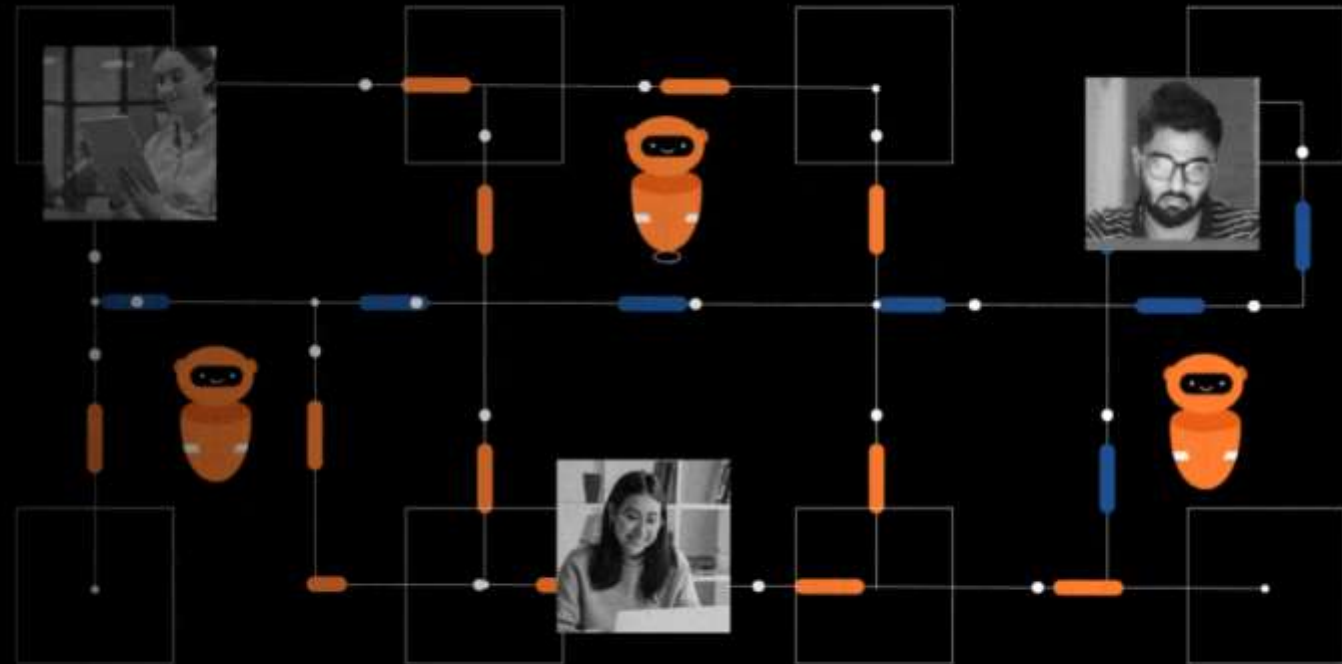

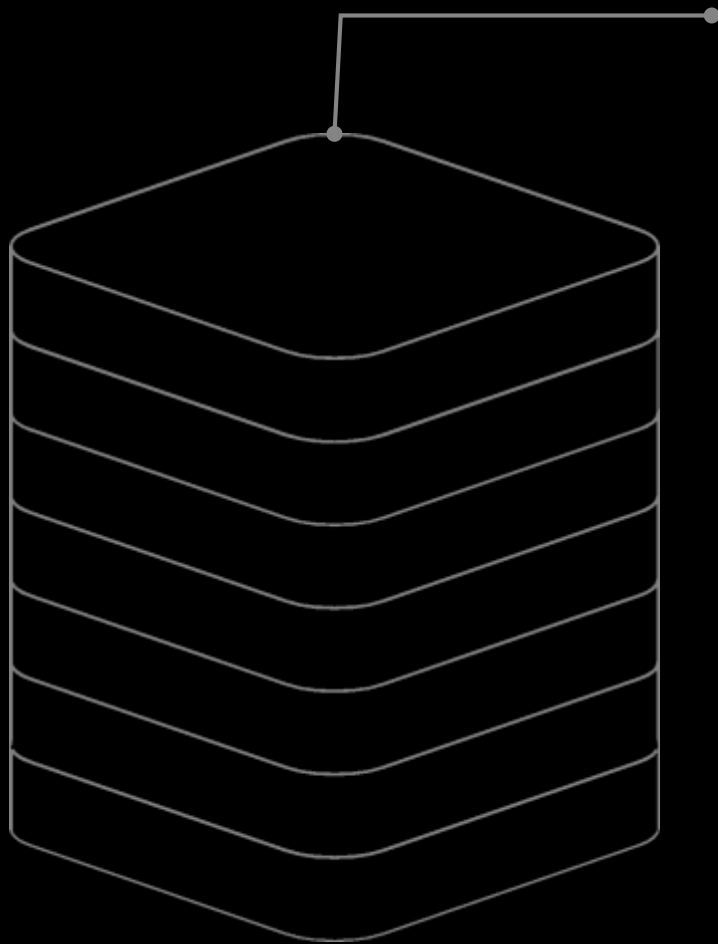
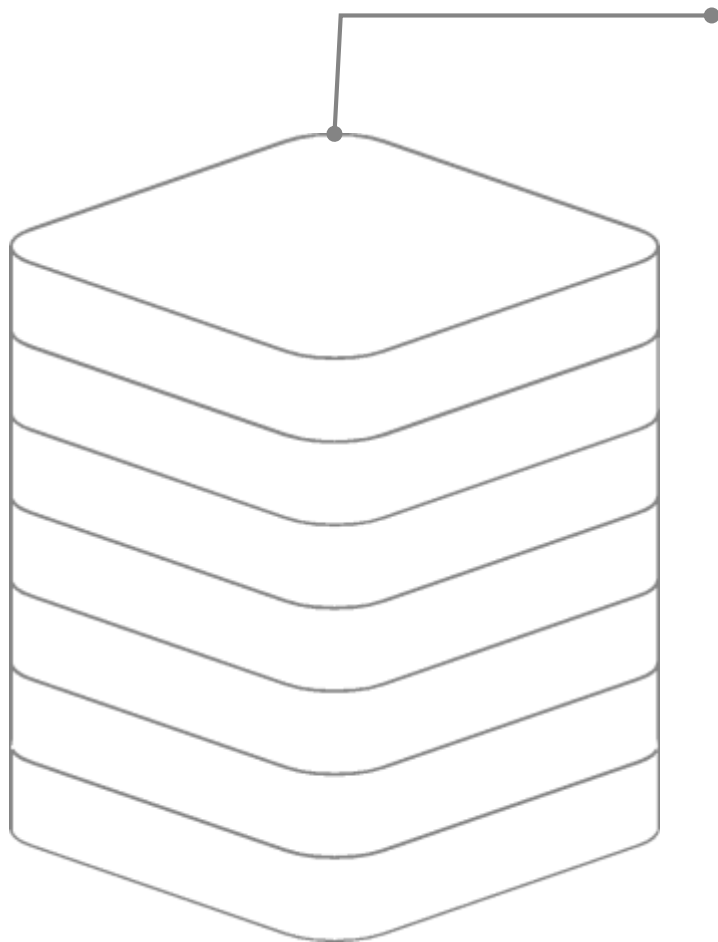

What stops rapid automation across organizations



50%

of RPA projects fail. They are often slow, centralized and target-led. ¹

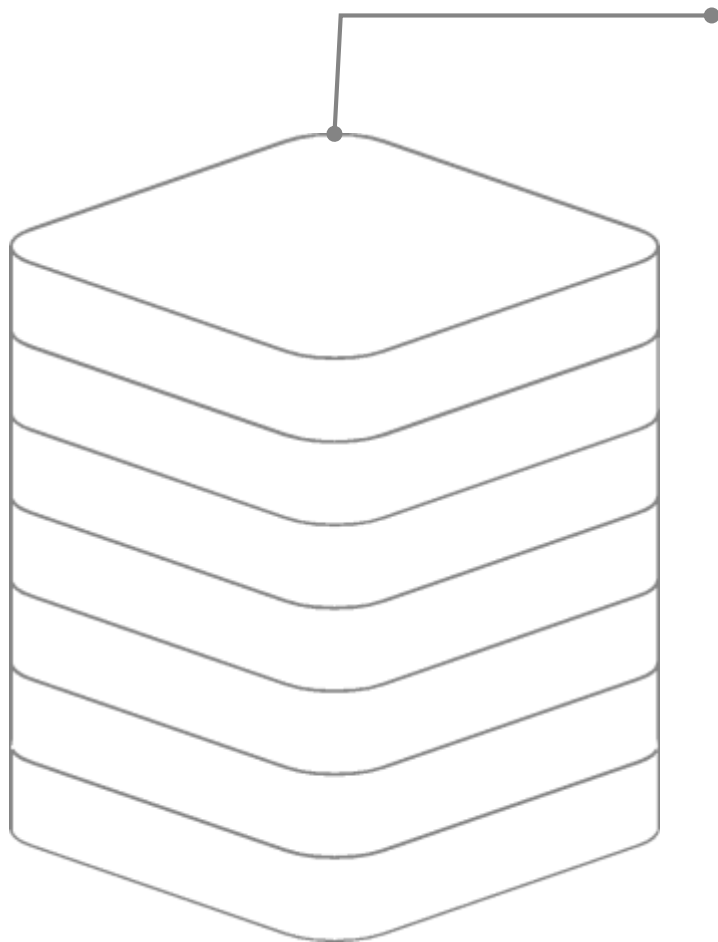

What stops rapid automation across organizations



50%

of RPA projects fail. They are often slow, centralized and target-led. ¹

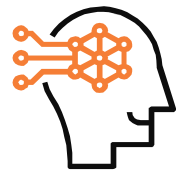

91%

of office workers believe their employers should be more willing to invest in digital and technology skills training. ²

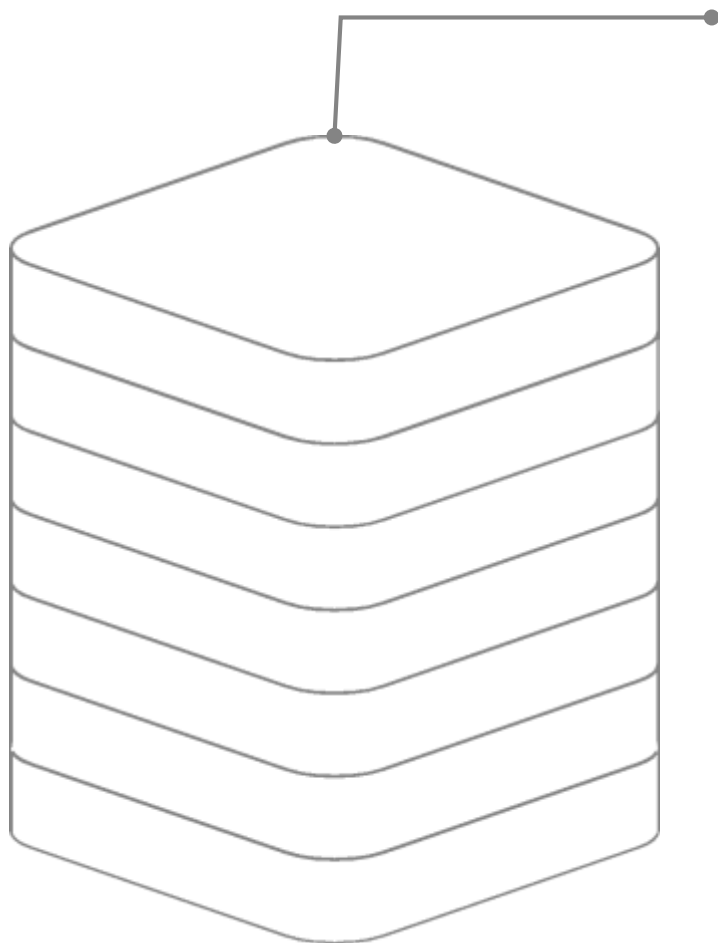

What stops rapid automation across organizations



50%

of RPA projects fail. They are often slow, centralized and target-led.¹

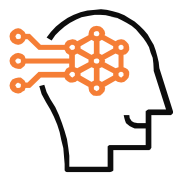

91%

of office workers believe their employers should be more willing to invest in digital and technology skills training.²

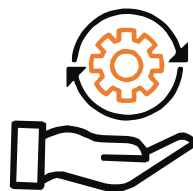

Try citizen development

by training people to exponentially increase the reach & value of automation.

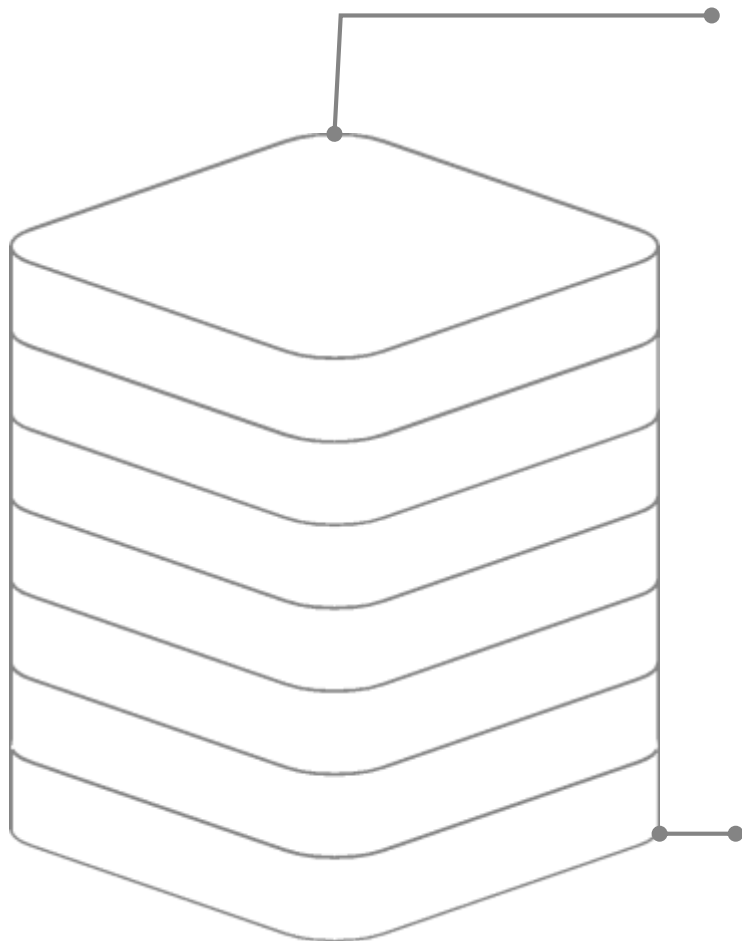

What stops rapid automation across organizations



50%

of RPA projects fail. They are often slow, centralized and target-led. ¹



91%

of office workers believe their employers should be more willing to invest in digital and technology skills training. ²

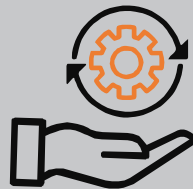

Try citizen development

by training people to exponentially increase the reach & value of automation.

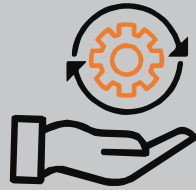
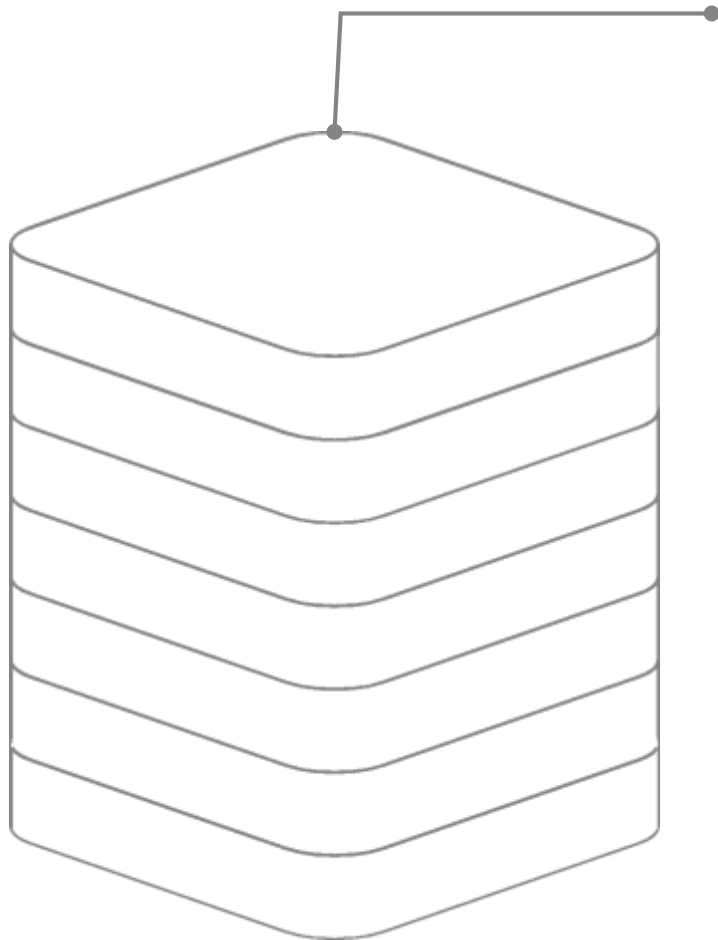

Our citizen development process

To find out what your employees are really capable of, follow our seven steps to successful citizen development

Step 1

Institutionalize standards to ensure quality, security and control

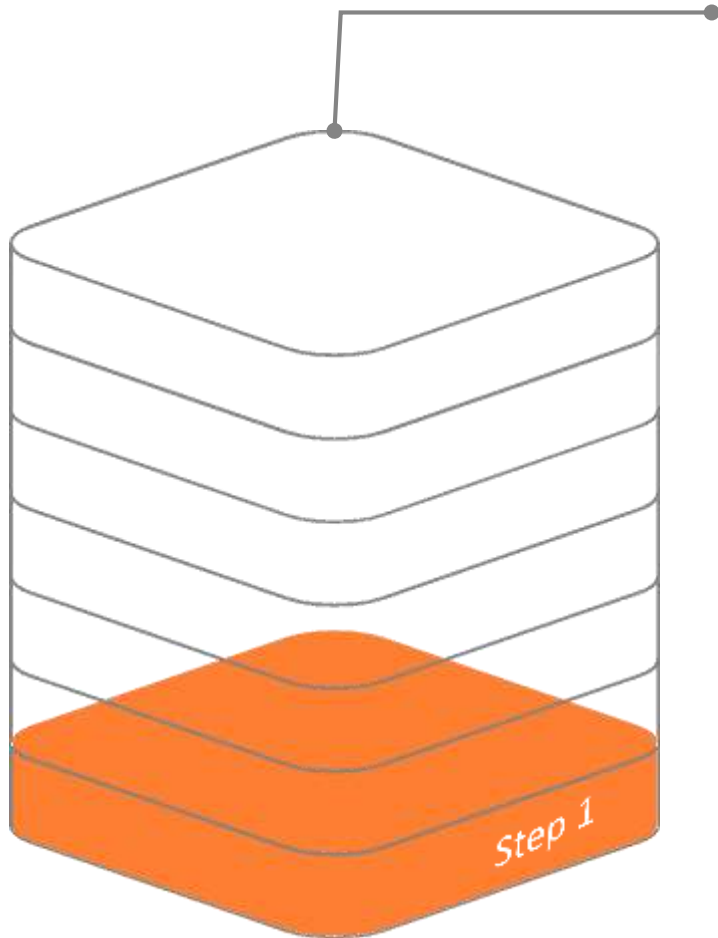

Step 2

Identifying the right business use cases that can be automated with potential return on investment

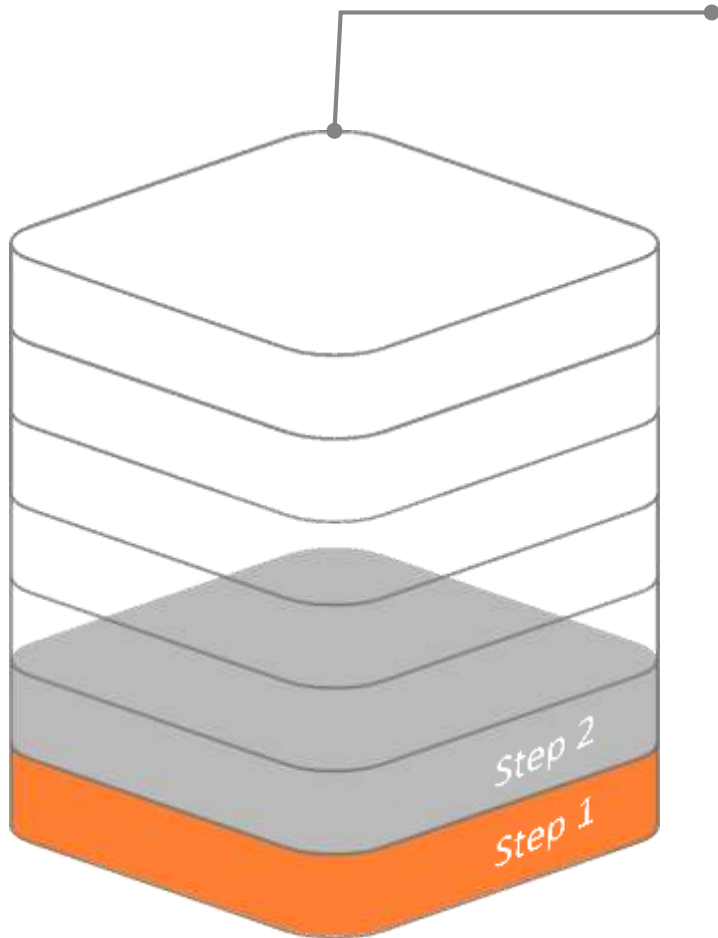

Step 3

Onboard citizen developers with training to develop an automation mindset through mentoring

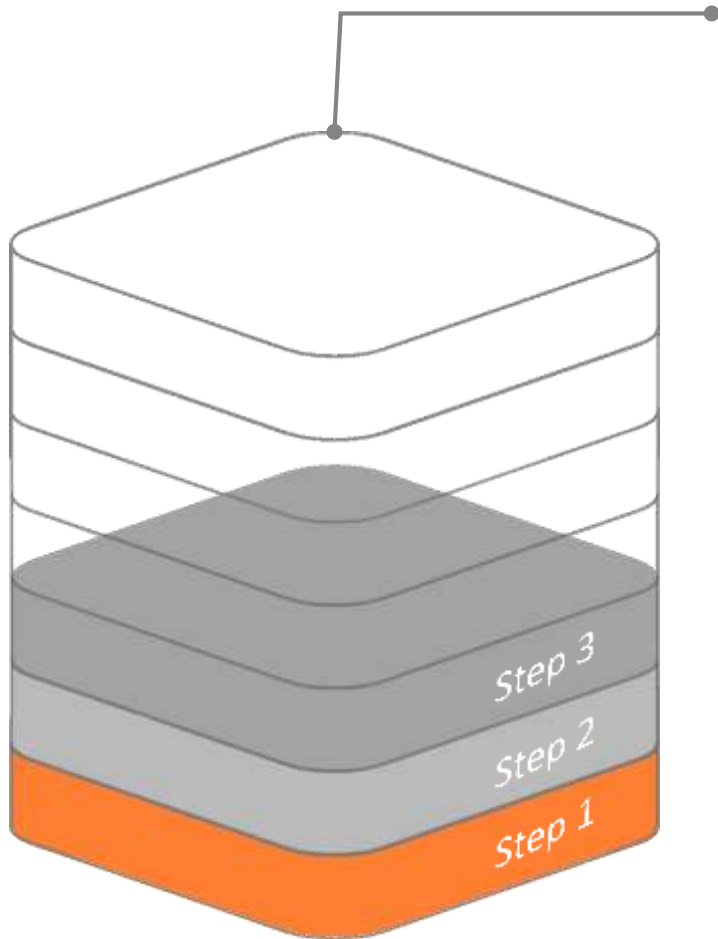

Step 4

Choose your citizen development no-code/low-code platform meeting the needs of both your end-users and your business

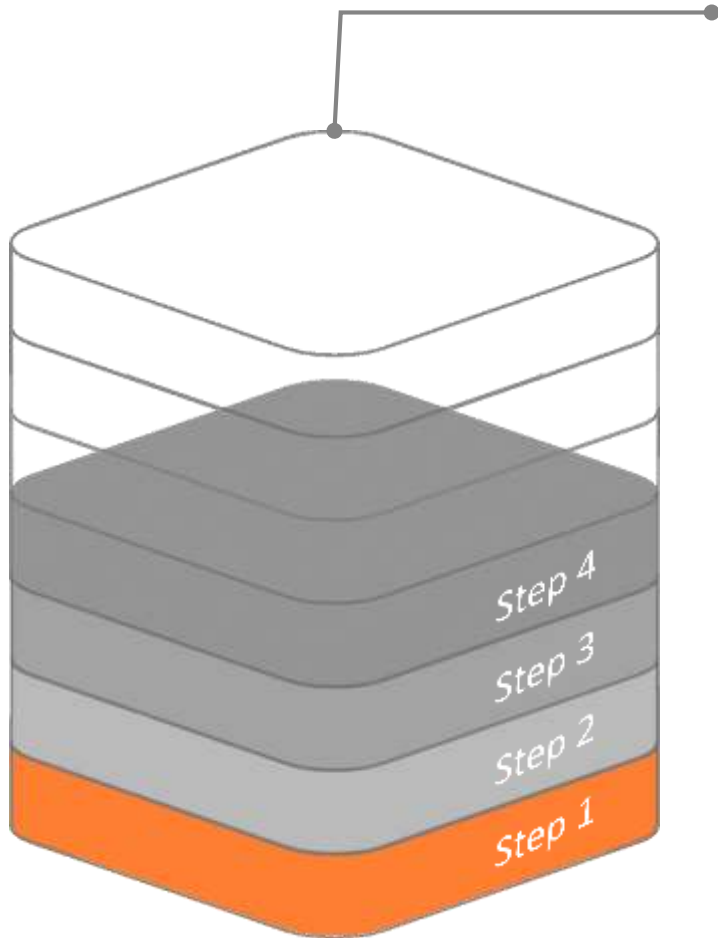

Step 5

Enable agile cross-functional teams for rapid prototyping and incremental delivery

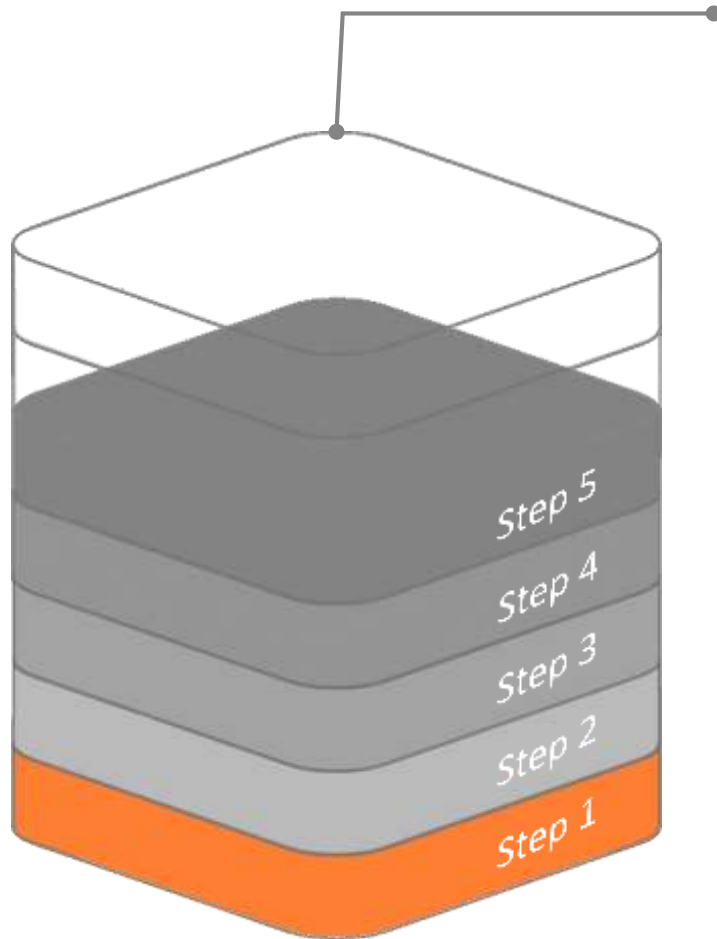

Step 6

Evaluate citizen-led automations for business impact and deployment across the organization

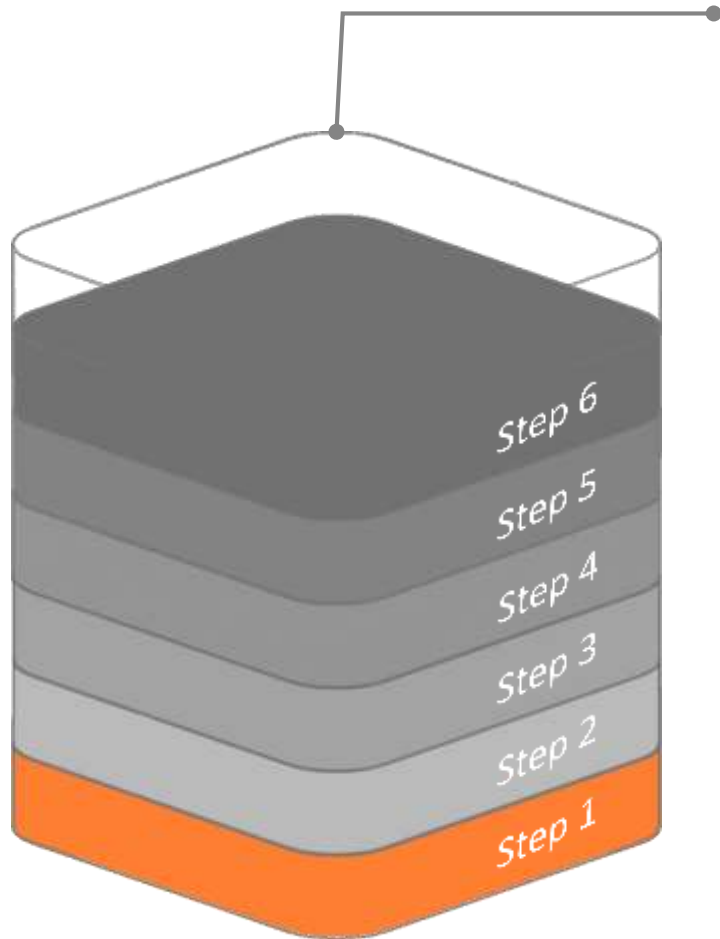

Step 7

Reward 'Power users' and watch them turn into program evangelists

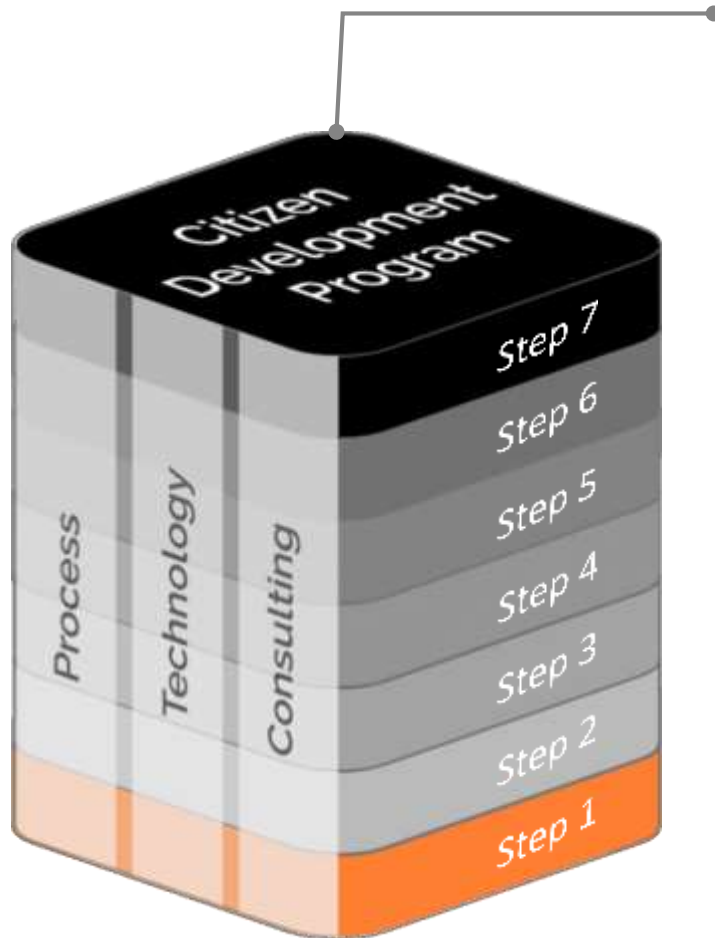

True digital transformation happens when



Bots are useful not mothballed



People are given the power to make their own jobs more interesting



Employees focus on higher-value tasks – and on their customers



IT can focus on major enterprise projects and automation is scaled faster



Employees feel invested in and cared for and their morale gets a huge boost



The best bots can be shared across teams

True digital transformation happens when



Bots are useful not mothballed



People are given the power to make their own jobs more interesting



Employees focus on higher-value tasks – and on their customers



IT can focus on major enterprise projects and automation is scaled faster



Employees feel invested in and cared for and their morale gets a huge boost



The best bots can be shared across teams

True digital transformation happens when



Bots are useful not mothballed



People are given the power to make their own jobs more interesting



Employees focus on higher-value tasks – and on their customers



IT can focus on major enterprise projects and automation is scaled faster



Employees feel invested in and cared for and their morale gets a huge boost



The best bots can be shared across teams

True digital transformation happens when



Bots are useful not mothballed



People are given the power to make their own jobs more interesting



Employees focus on higher-value tasks – and on their customers



IT can focus on major enterprise projects and automation is scaled faster



Employees feel invested in and cared for and their morale gets a huge boost



The best bots can be shared across teams

True digital transformation happens when



Bots are useful not mothballed



People are given the power to make their own jobs more interesting



Employees focus on higher-value tasks – and on their customers



IT can focus on major enterprise projects and automation is scaled faster



Employees feel invested in and cared for and their morale gets a huge boost



The best bots can be shared across teams

True digital transformation happens when



Bots are useful not mothballed



People are given the power to make their own jobs more interesting



Employees focus on higher-value tasks – and on their customers



IT can focus on major enterprise projects and automation is scaled faster



Employees feel invested in and cared for, and their morale gets a huge boost



The best bots can be shared across teams

True digital transformation happens when



Bots are useful not mothballed



People are given the power to make their own jobs more interesting



Employees focus on higher-value tasks – and on their customers



IT can focus on major enterprise projects and automation is scaled faster



Employees feel invested in and cared for and their morale gets a huge boost



The best bots can be shared across teams



We tested **citizen development** across **two of our largest business units**. Within 4 months, citizen developers **developed** more than **100 bots**.



We achieved



We achieved

A horizontal line with a white circle at the end, indicating a progress or achievement level.

95%
hike in
efficiency



We achieved





We achieved

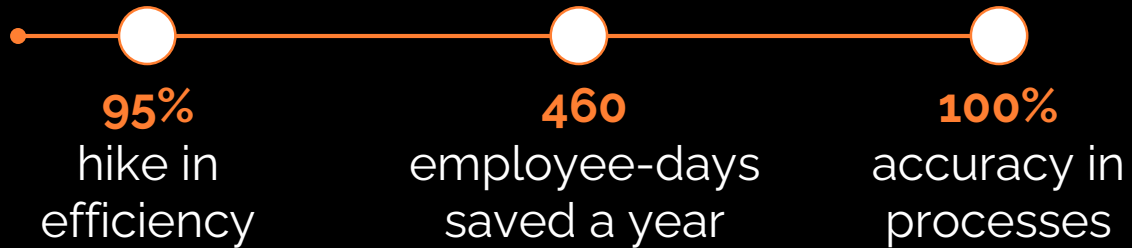



We achieved





We achieved

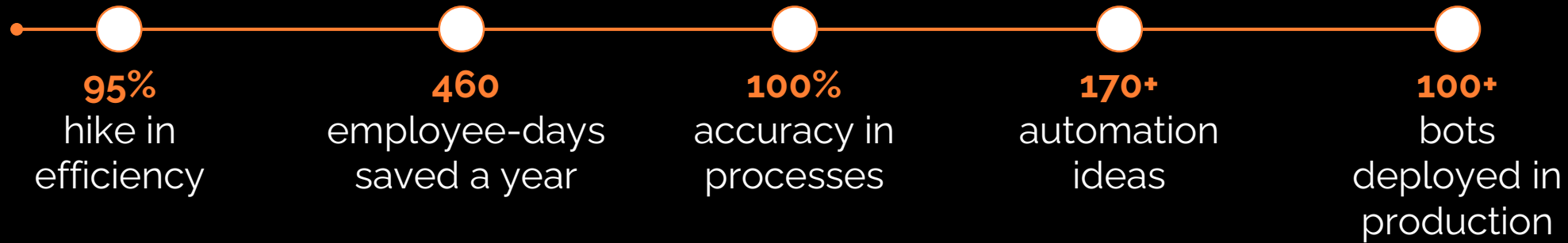



We achieved





Citizen Development Program

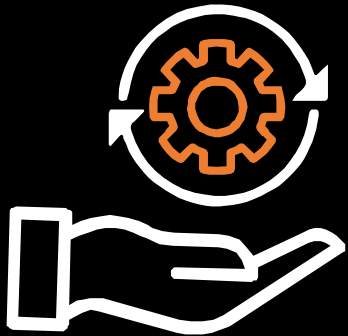

If you want to turbo-charge your digital transformation, scale automation, and discover what your people are truly capable of, check out the complete infographic here:

<https://www.firstsource.com/citizen-development-infographic/#citi-develop>

Helping customers *stay ahead of the curve* through transformational technologies and capabilities

Firstsource Solutions Limited, an RP-Sanjiv Goenka Group company, is a leading provider of transformational solutions and services spanning the customer lifecycle across Healthcare, Banking and Financial Services, Communications, Media and Technology and other industries.

Our 'Digital First, Digital Now' approach helps organizations reinvent operations and reimagine business models, enabling them to deliver moments that matter and build competitive advantage.

With an established presence in the US, the UK, India and the Philippines, we act as a trusted growth partner for over 100 leading global brands, including several Fortune 500 and FTSE 100 companies.

www.firstsource.com

